

<small>PROPRIETARY AND CONFIDENTIAL THIS DOCUMENT AND ALL INFORMATION HEREIN IS THE PROPERTY OF KNOX HANCOCK AND MAY NOT BE REPRODUCED WITHOUT THEIR WRITTEN PERMISSION.</small>		<small>UNLESS OTHERWISE SPECIFIED: DIMENSIONS ARE IN INCHES FRACTIONS ARE FRACTIONS ANGULAR MEASUREMENTS TWO PLACE DECIMAL THREE PLACE DECIMAL TOLERANCES ARE: DIMENSIONS ARE: 6061-ALUM. Anodized</small>	<small>DATE</small> <small>NAME</small> <small>DRAWN</small> <small>CHECKED</small> <small>ENG APPR</small> <small>MFG APPR</small> <small>QA</small> <small>COMMENTS</small>	<small>TITLE</small> <b>DH1000</b> <small>SIZE</small> <b>E</b> <small>DWG. NO.</small> <b>05252007</b> <small>SCALE: 1:2</small>	<small>REV</small> <b>1</b> <small>SHEET 1 OF 2</small>
--	--	--	--	---	---

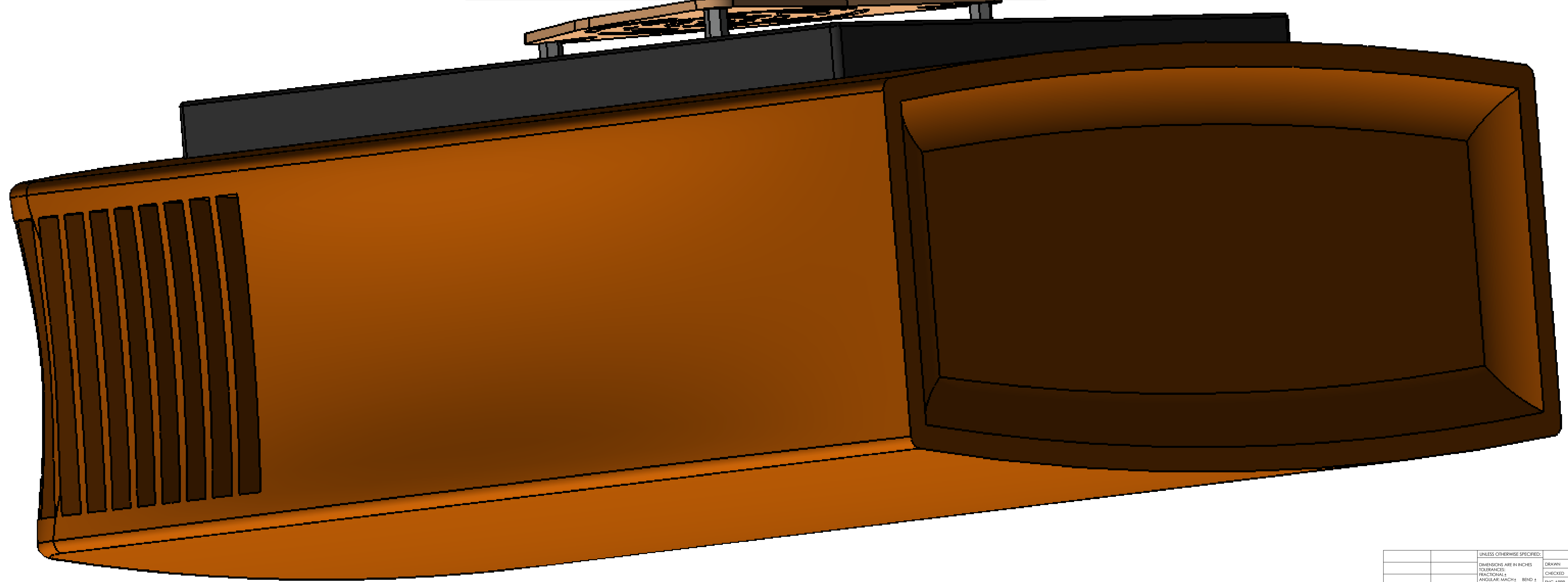
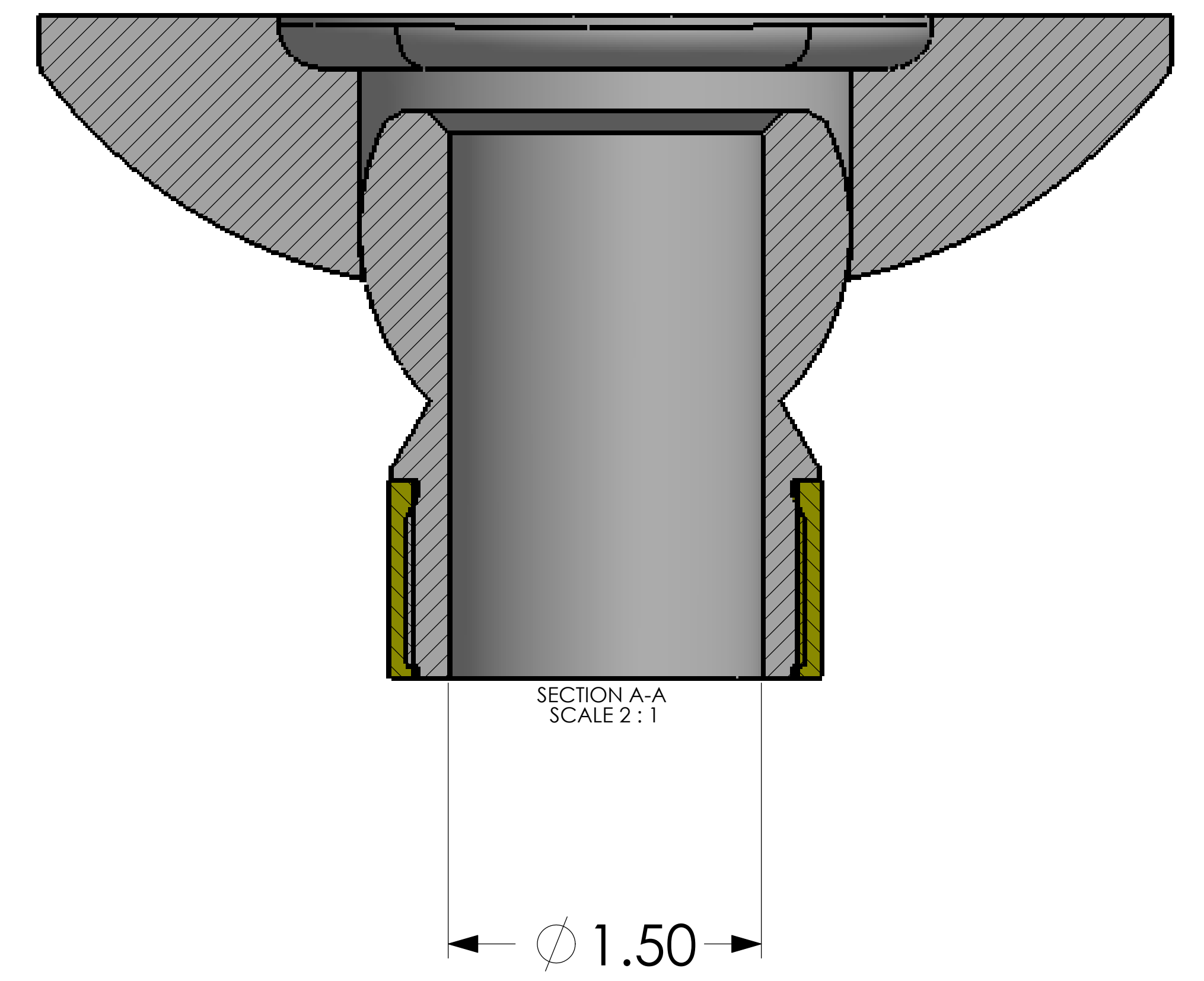
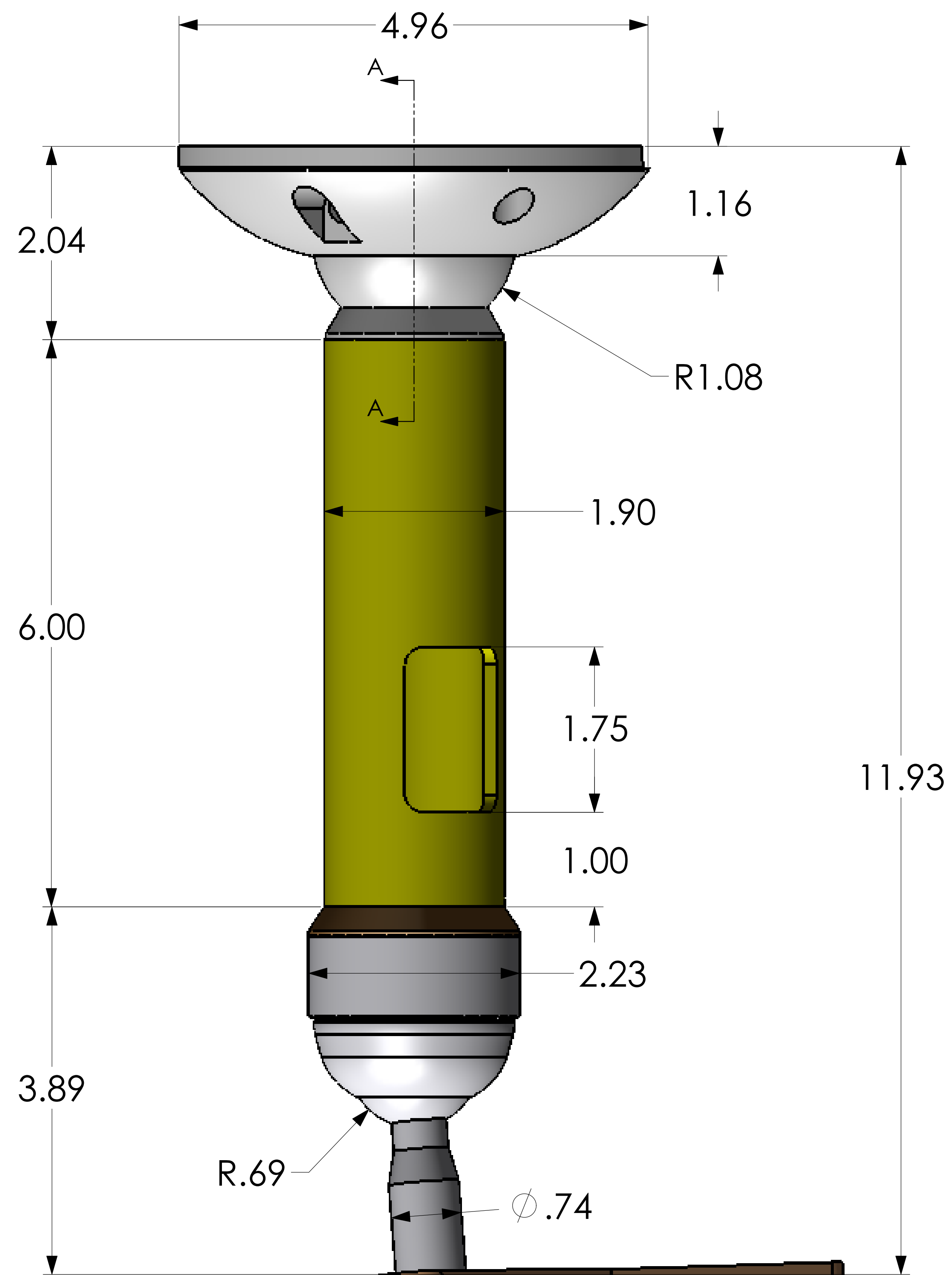
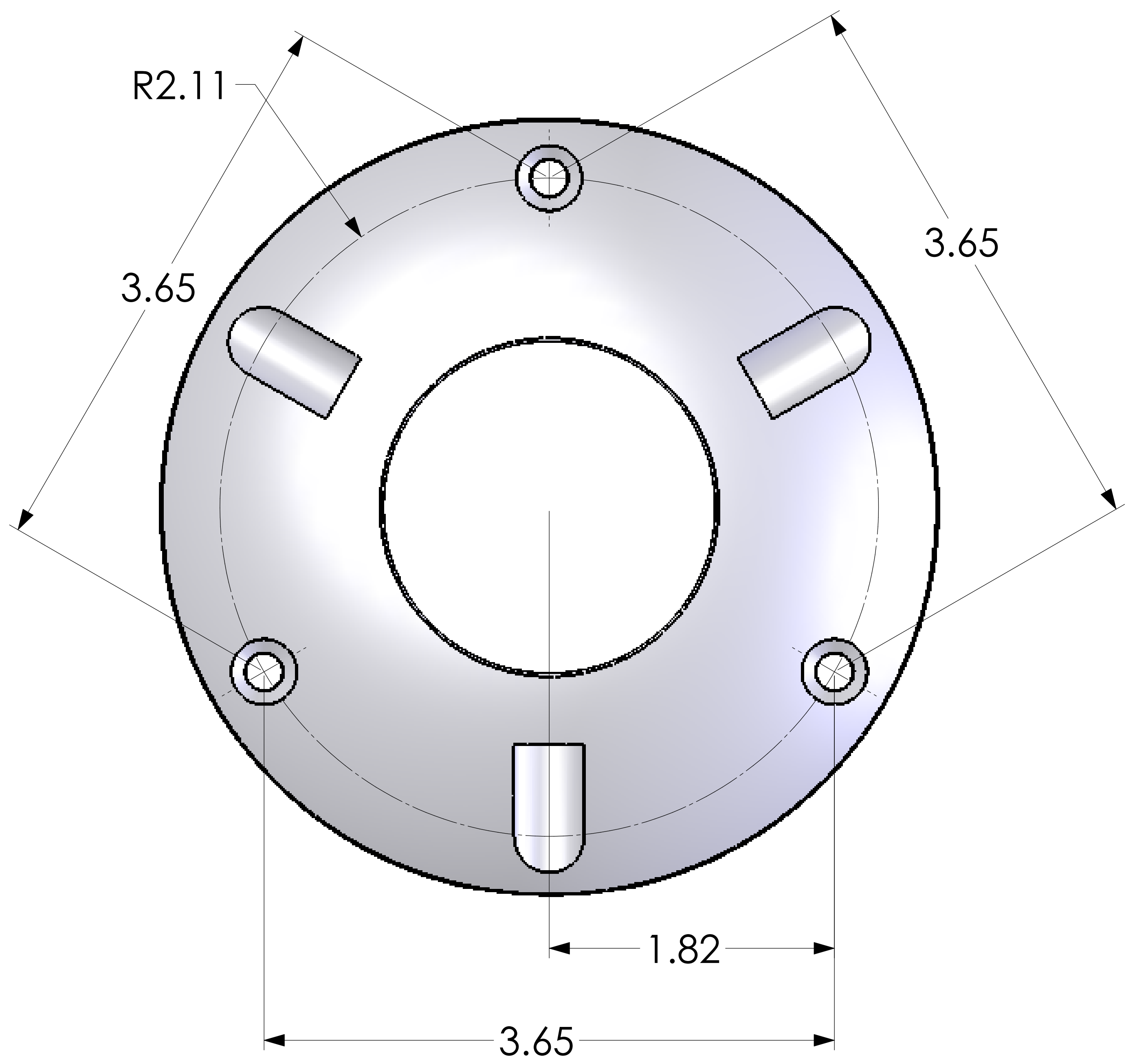

UNLESS OTHERWISE SPECIFIED:		DATE	
ALL DIMENSIONS ARE IN INCHES	DRAWN	NAME	
FRACTIONS ARE TO BE SHOWN AS DECIMALS	CHECKED	VERIFIED	
ANGULAR DIMENSIONS ARE TO BE SHOWN AS DECIMALS	ENG APPR		
TWO PLACE DECIMALS	DATE		
THREE PLACE DECIMALS	Q.A.		
FOUR PLACE DECIMALS	CONTRACT		
	4061-ALUM		
	FRSP		
	ISSUED ON		
	APPLICATION		
PROPERTY AND CONFIDENTIAL INFORMATION AND ALL INFORMATION HEREON IS THE PROPERTY OF HANFORD AND MAY NOT BE REPRODUCED WITHOUT THEIR WRITTEN PERMISSION		TITLE: DH1000 Ceiling Mount	
SIZE	DWG. NO.	REV	
E	SCALE: 1:2	SHEET 2 OF 2	