

UNLESS OTHERWISE SPECIFIED: DIMENSIONS ARE IN INCHES FRACTIONS ARE IN 16THS OF AN INCH DECIMALS ARE TO THE NEAREST 0.001 INCH TOLERANCES ARE: FRACTIONS: ±0.005 DECIMALS: ±0.005		DATE	NAME	DRAWN	CHECKED	TITLE
MATERIALS AND FINISHES: UNLESS OTHERWISE SPECIFIED: STEEL: A36 ALUMINUM: 6061-T6 ZINC PLATE				Vernis		DH1000
FINISH: ANODIZED						REV 1
SCALE: 1:2		DWG. NO. 05252007		SHEET 1 OF 2		

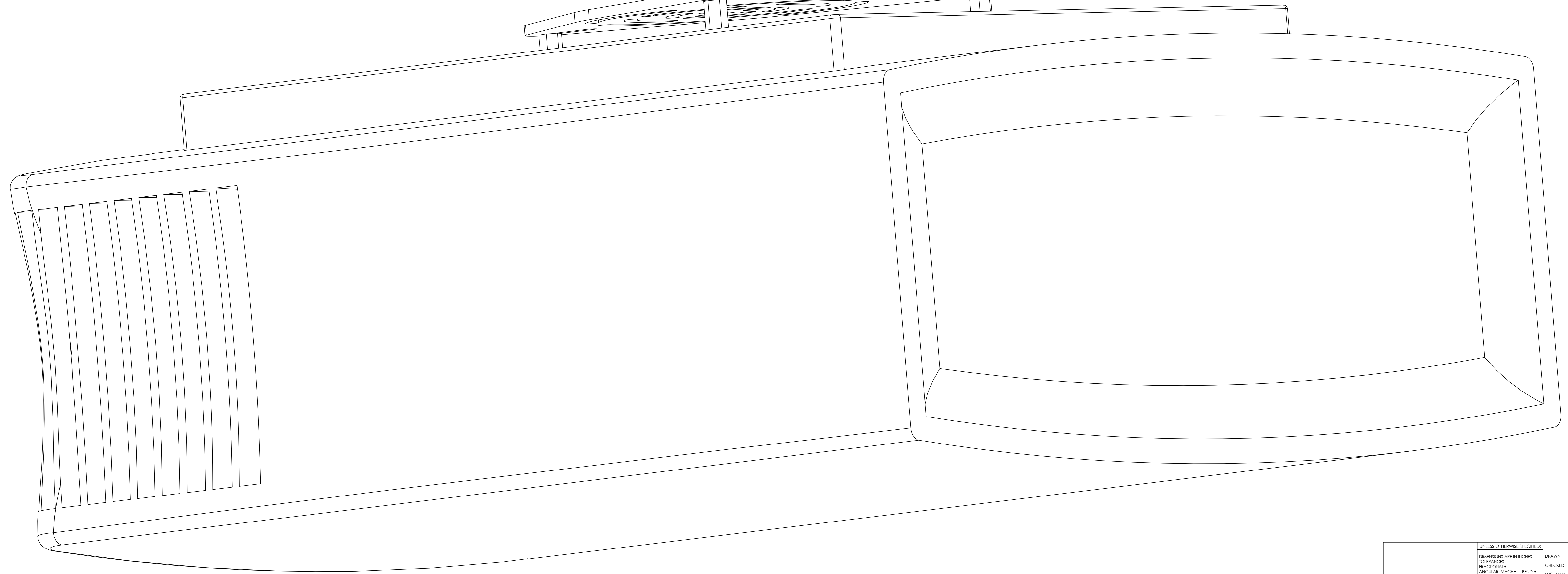
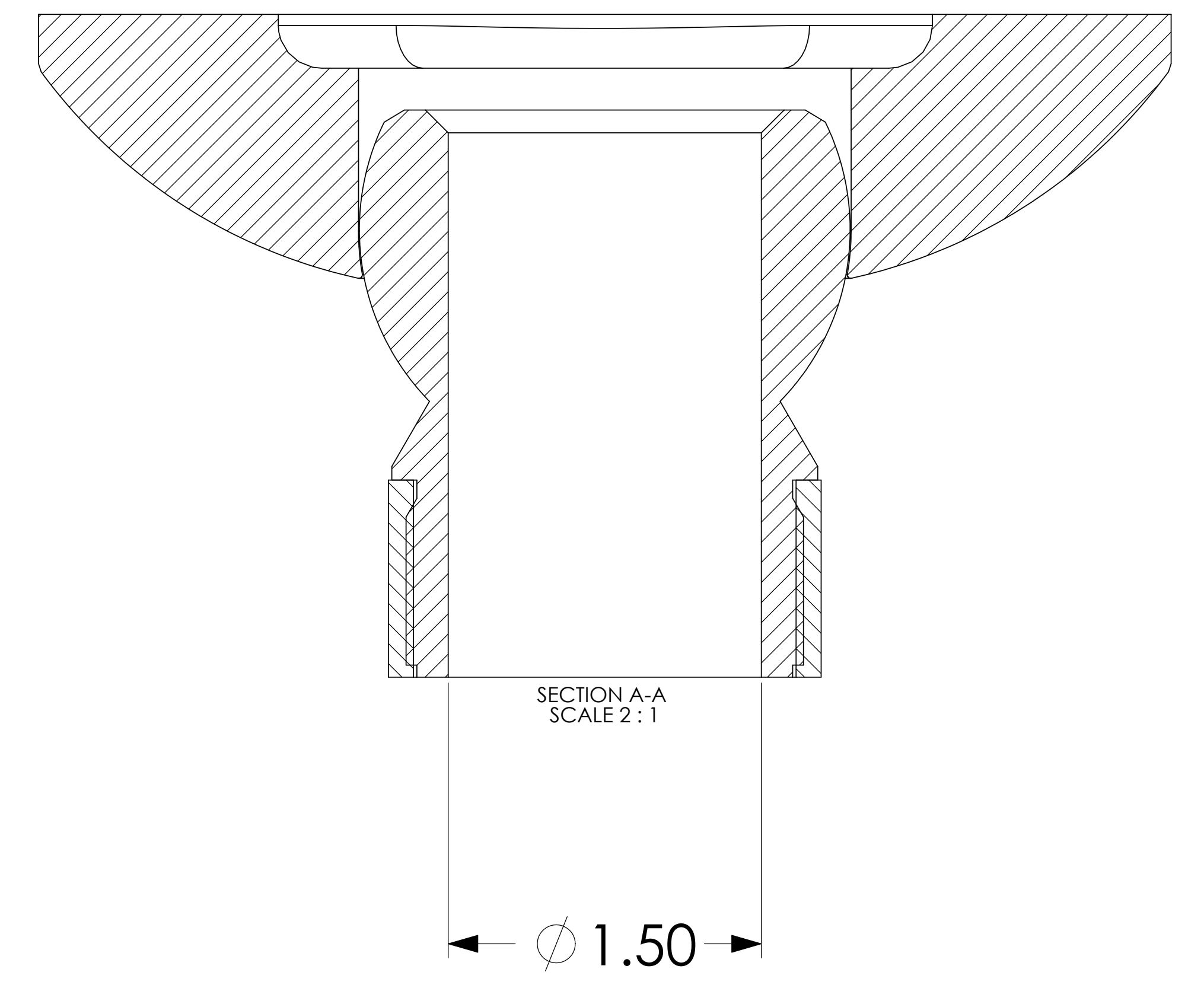
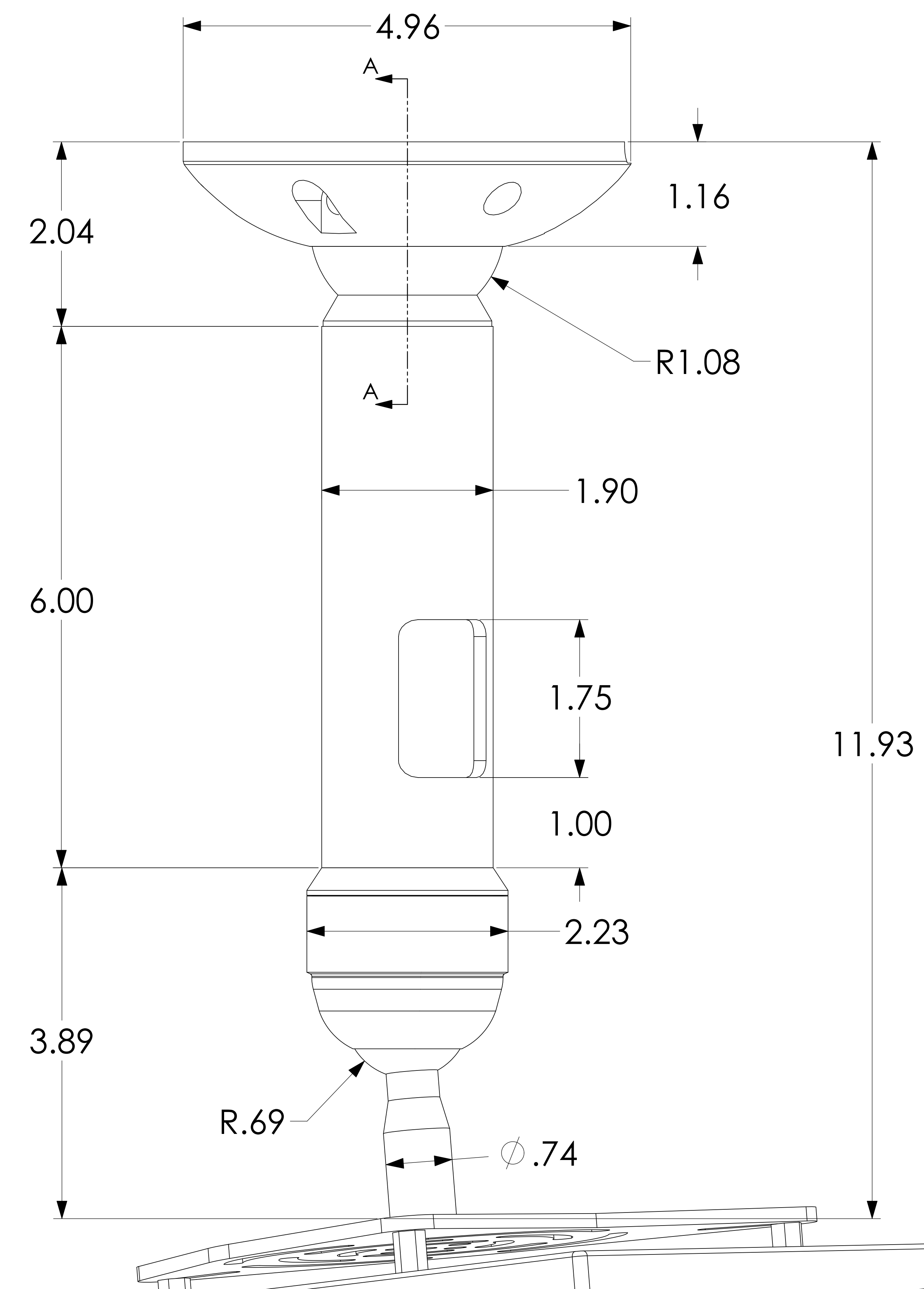
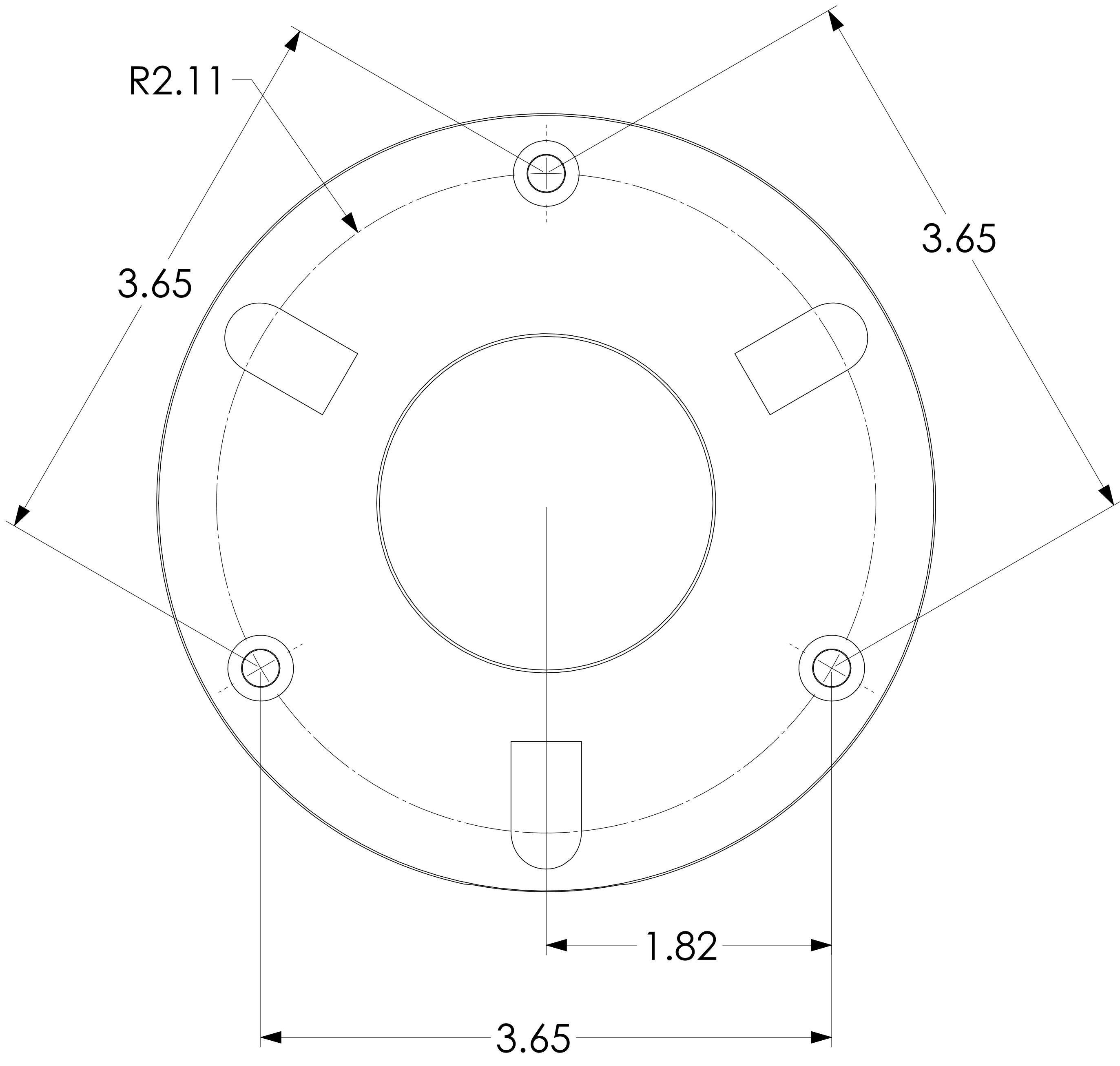

UNLESS OTHERWISE SPECIFIED:		NAME	DATE
TO DIMENSIONS:	DRAWN		
FRACTIONS:	CHECKED		
DECIMALS:	BY		
TWO PLACE DECIMAL:	DATE		
THREE PLACE DECIMAL:			
FOUR PLACE DECIMAL:			
OTHER:			
INTERPRET GEOMETRIC CONSTRUCTIONS:	DATE		
CONSTRUCTION:			
DATE:			
SCALE:			
APPROVAL:			
DATE:			
APPLICATION:			

PROPERTY AND CONFIDENTIALITY NOTICE: THIS DOCUMENT AND ALL INFORMATION HEREON IS THE PROPERTY OF THE COMPANY AND SHALL REMAIN CONFIDENTIAL AND NOT BE REPRODUCED WITHOUT THE WRITTEN PERMISSION OF THE COMPANY.

PROPRIETARY AND CONFIDENTIAL

THIS DOCUMENT AND ALL INFORMATION HEREON IS THE PROPERTY OF THE COMPANY AND SHALL REMAIN CONFIDENTIAL AND NOT BE REPRODUCED WITHOUT THE WRITTEN PERMISSION OF THE COMPANY.

DATE: 11/11/11

SCALE: 1:2

SIZE: 11x17

DWG. NO.: DH1000

REV: 1

SHEET 2 OF 2